

10. Diagnostic Chart with Select Monitor

A: BASIC DIAGNOSTIC CHART

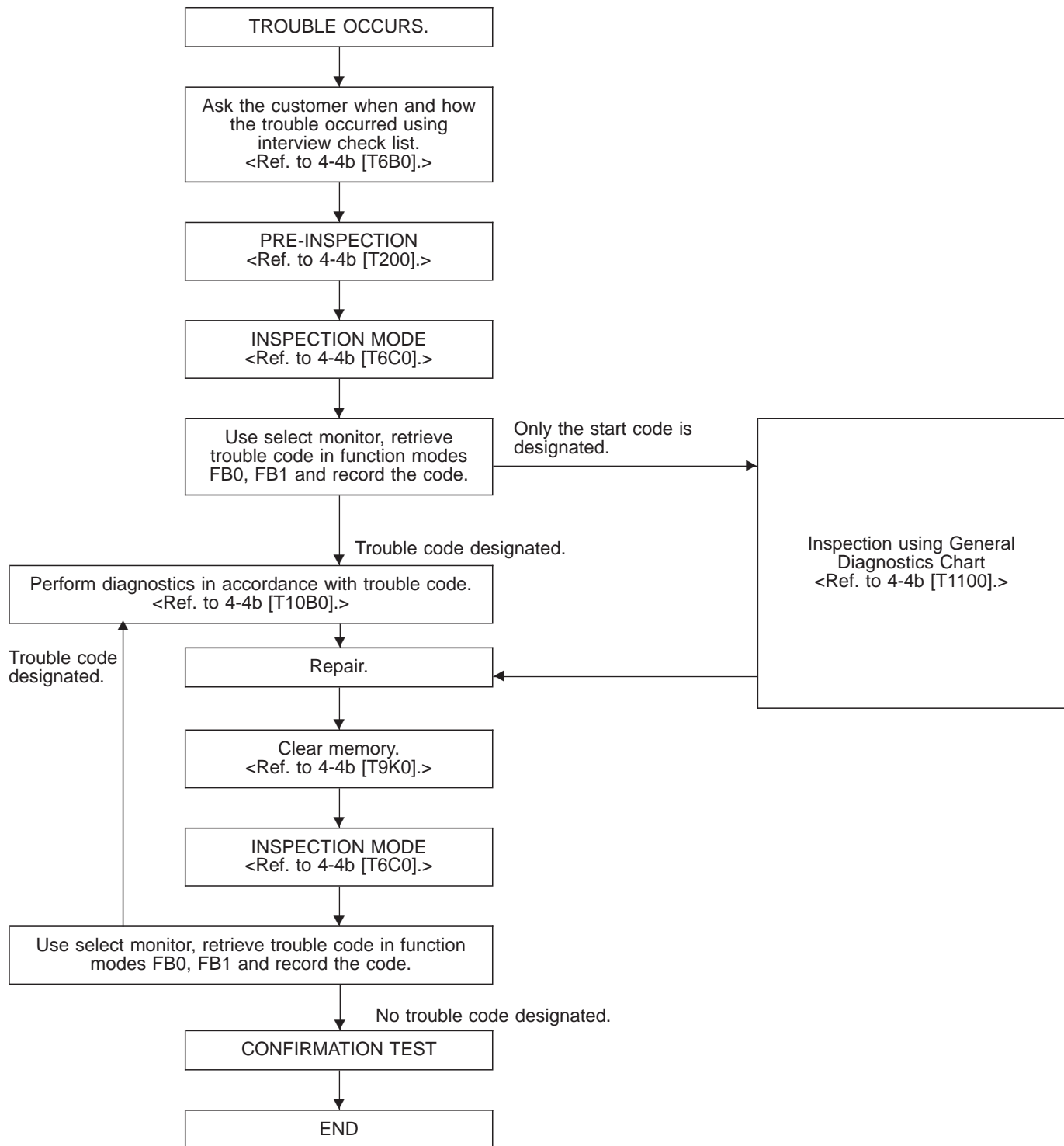

NOTE:

To check harness for broken wires or short circuits, shake it while holding it or the connector.

B: LIST OF TROUBLE CODE

Diagnostic items (select monitor FB0)	Code	Display screen (FB0)	Diagnostic items (select monitor FB1)	Display screen (FB1)	Ref. to 4-4b
Normal	11	NO TROUBLE	Normal	NO TROUBLE	[T10C0]
Detection of FR sensor hardware	21	FR.SS HARD	Open circuit of FR sensor	FR.SS OPEN	[T10D1]
			Short circuit of FR sensor	FR.SS SHORT	[T10D2]
Detection of FR sensor software	22	FR.SS SOFT	FR sensor, variations in wheel speed	FR.SS W.SPEED	[T10E1]
			FR sensor, reduced pressure mode	FR.SS OR MV	[T10E2]
			FR sensor, wheel speed higher than prescribed	FR.SS OVER	[T10E3]
Detection of FL sensor hardware	23	FL.SS HARD	Open circuit of FL sensor	FL.SS OPEN	[T10F1]
			Short circuit of FL sensor	FL.SS SHORT	[T10F2]
Detection of FL sensor software	24	FL.SS SOFT	FL sensor, variations in wheel speed	FL.SS W.SPEED	[T10G1]
			FL sensor, reduced pressure mode	FL.SS OR MV	[T10G2]
			FL sensor, wheel speed higher than prescribed	FL.SS OVER	[T10G3]
Detection of RR sensor hardware	25	RR.SS HARD	Open circuit of RR sensor	RR.SS OPEN	[T10H1]
			Short circuit of RR sensor	RR.SS SHORT	[T10H2]
Detection of RR sensor software	26	RR.SS SOFT	RR sensor, variations in wheel speed	RR.SS W.SPEED	[T10I1]
			RR sensor, reduced pressure mode	RR.SS OR MV	[T10I2]
			RR sensor, wheel speed higher than prescribed	RR.SS OVER	[T10I3]
Detection of RL sensor hardware	27	RL.SS HARD	Open circuit of RL sensor	RL.SS OPEN	[T10J1]
			Short circuit of RL sensor	RL.SS SHORT	[T10J2]
Detection of RL sensor software	28	RL.SS SOFT	RL sensor, variations in wheel speed	RL.SS W.SPEED	[T10K1]
			RL sensor, reduced pressure mode	RL.SS OR MV	[T10K2]
			RL sensor, wheel speed higher than prescribed	RL.SS OVER	[T10K3]
Abnormal FR.IN valve	31	FR.IN VALVE	Abnormal FR.IN valve	FR.IN VALVE	[T10L0]
Abnormal FR.OUT valve	32	FR.OUT VALVE	Abnormal FR.OUT valve	FR.OUT VALVE	[T10M0]
Abnormal FL.IN valve	33	FL.IN VALVE	Abnormal FL.IN valve	FL.IN VALVE	[T10N0]
Abnormal FL.OUT valve	34	FL.OUT VALVE	Abnormal FL.OUT valve	FL.OUT VALVE	[T10O0]
Abnormal RR.IN valve	35	RR.IN VALVE	Abnormal RR.IN valve	RR.IN VALVE	[T10P0]
Abnormal RR.OUT valve	36	RR.OUT VALVE	Abnormal RR.OUT valve	RR.OUT VALVE	[T10Q0]
Abnormal RL.IN valve	37	RL.IN VALVE	Abnormal RL.IN valve	RL.IN VALVE	[T10R0]
Abnormal RL.OUT valve	38	RL.OUT VALVE	Abnormal RL.OUT valve	RL.OUT VALVE	[T10S0]
Abnormal ECM	41	ECU	Abnormal ECM	ECU	[T10T0]
Abnormal line voltage	42	HIGH VOLTAGE	Abnormal line voltage	HIGH VOLTAGE	[T10U0]
Abnormal EGI communication line	43	EGI LINE	Abnormal EGI communication line	EGI LINE	[T10V0]
Abnormal valve relay	51	V.RELAY	Valve relay ON failure	V.RELAY ON	[T10W1]
			Valve relay OFF failure	V.RELAY OFF	[T10W2]
Abnormal motor system	52	MOTOR	Motor relay ON failure	MOTOR ON	[T10X1]
			Motor relay OFF failure	MOTOR OFF	[T10X2]

Diagnostic items (select monitor FB0)	Code	Display screen (FB0)	Diagnostic items (select monitor FB1)	Display screen (FB1)	Ref. to 4-4b
Abnormal stroke sensor and stop light switch	54	PSS & BLS	Open/short circuits of stroke sensor	B.SW HARD	[T10Y1]
			Comparison of stroke sensor and acceleration	B.SW SOFT(G)	[T10Y2]
			Comparison of stroke sensor and stop light switch	B.SW SOFT(B)	[T10Y3]
			Comparison of stroke sensor and pump	B.SW SOFT(P)	[T10Y4]
			Open circuit of stop light switch	B.SW SOFT(O)	[T10Y5]
Abnormal fluid level sensor line	57	FLUID LEVEL SS	Abnormal fluid level sensor line	FLUID LEVEL SS	[T10Z0]
Abnormal pressure switch	58	PRESSURE SW	Abnormal pressure switch	PRESSURE SW	[T10AA0]
Abnormal TCS1 valve	61	TCS1 VALVE	Abnormal TCS1 valve	TCS1 VALVE	[T10AB0]
Abnormal TCS2 valve	62	TCS2 VALVE	Abnormal TCS2 valve	TCS2 VALVE	[T10AC0]

1. IF THE SELECT MONITOR IS USED FOR TROUBLESHOOTING, IT IS ADVISED TO FOLLOW THE PROCEDURE BELOW

- 1) Activate function FB0 to read the most recent trouble code and record it.
- 2) Activate function FB1 to read all trouble codes and record them.

(If troubles occur in the wheel speed sensor, stop & brake switch, valve relay or motor system, detailed data on troubles are displayed by the FB1 function, allowing you to easily locate points where need repair.)

- 3) Perform troubleshooting mainly in the FB1 mode.

D . ALL 11 (FB1)

NO TROUBLE

B4M0490

C: TROUBLE CODE 11

— NO TROUBLE —

DIAGNOSIS:

- ABS/TCS control module does not store troubles.

D . ALL 21 (FB1)

FR . SS OPEN

B4M0491

D: TROUBLE CODE 21

1. FR.SS OPEN

— Faulty front right ABS sensor (Open circuit) —

DIAGNOSIS:

- Faulty ABS sensor
- Faulty harness and connector
- Faulty ABS/TCS control module

TROUBLE SYMPTOM:

- ABS does not operate.
- TCS does not operate.

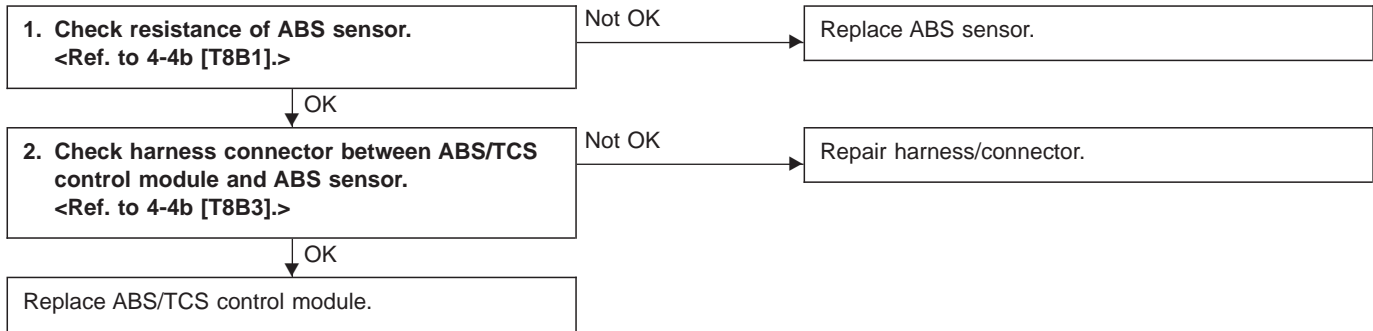

NOTE:

When checking ABS sensor, carefully bend or swing connector and harness to check for improper contacts or open circuits.

D . ALL 21 (FB1)

FR . SS SHORT

B4M0492

2. FR.SS SHORT

— **Faulty front right ABS sensor (Short circuit)** —

DIAGNOSIS:

- Faulty ABS sensor
- Faulty harness and connector
- Faulty ABS/TCS control module

TROUBLE SYMPTOM:

- ABS and TCS do not operate.
- TCS does not operate.

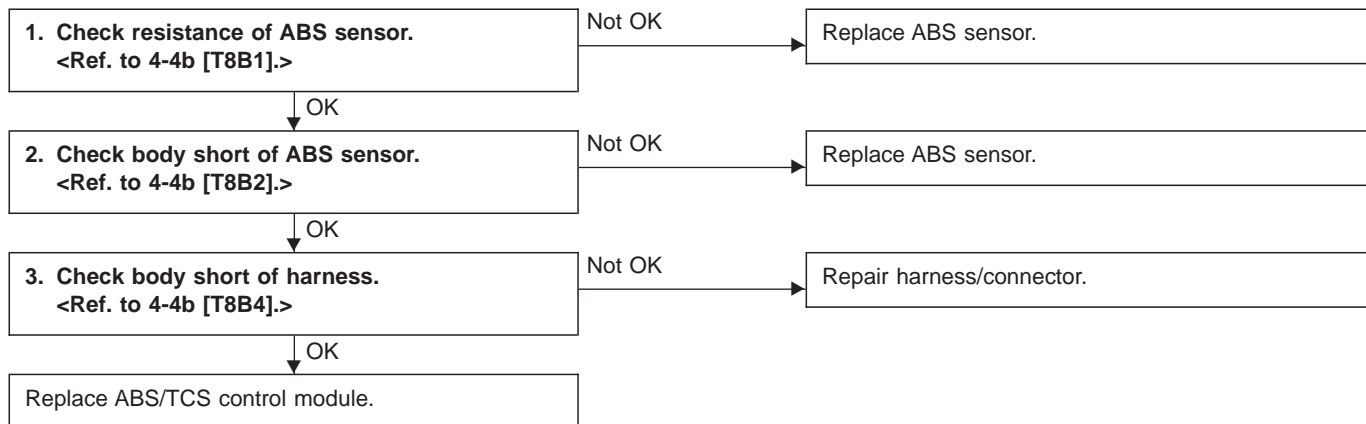

NOTE:

When checking ABS sensor, carefully bend or swing connector and harness to check for improper contacts or open circuits.

D . ALL 22 (FB1)

FR . SS W. SPEED

B4M0493

E: TROUBLE CODE 22

1. FR.SS W.SPEED

— Irregular signals from front right ABS sensor —

DIAGNOSIS:

- Faulty ABS sensor signal (noise, irregular signal, etc.)
- Faulty harness/connector
- Faulty ABS/TCS control module

TROUBLE SYMPTOM:

- ABS and TCS do not operate.

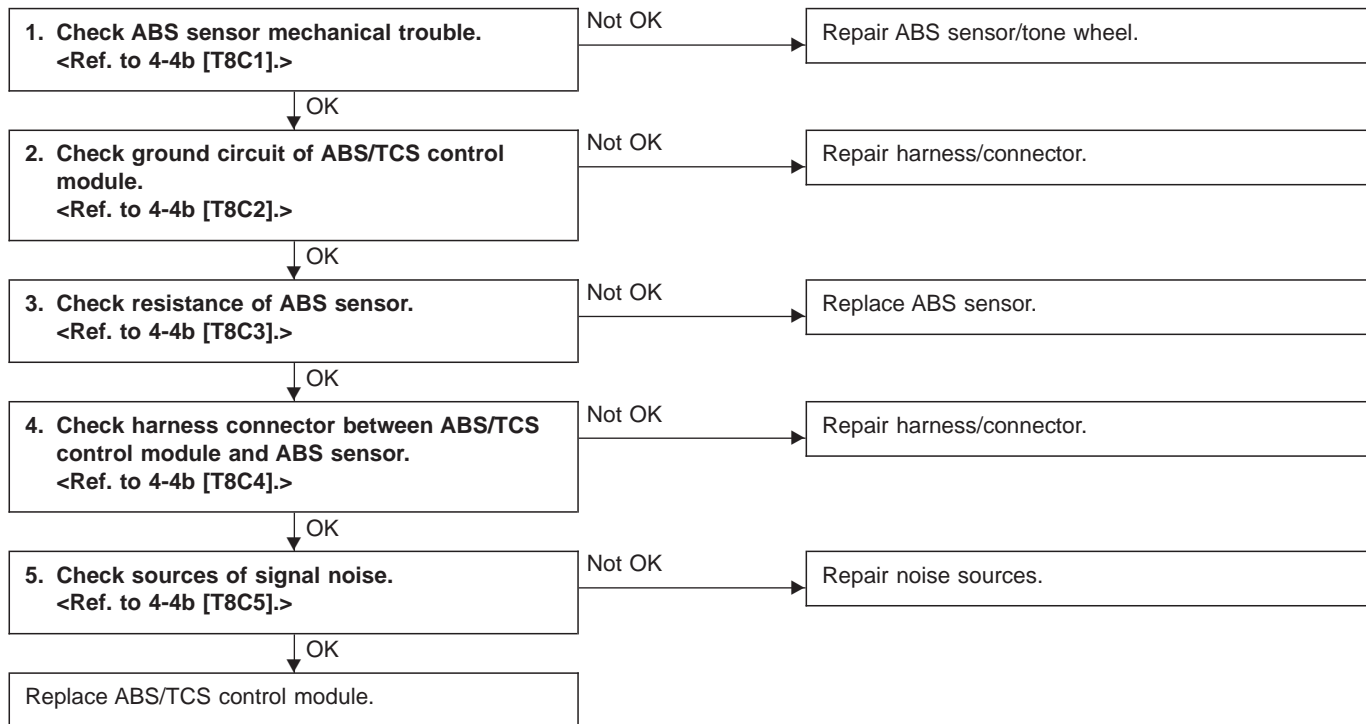

D. ALL 22 (FB1)

FR. SS OR MV

B4M0494

2. FR.SS OR MV

— Irregular signals from front right ABS sensor in decompressing mode —

DIAGNOSIS:

- Faulty ABS sensor signal (noise, irregular signal, etc.)
- Faulty hydraulic unit
- Faulty harness/connector
- Faulty ABS/TCS control module

TROUBLE SYMPTOM:

- ABS does not operate.
- TCS does not operate.

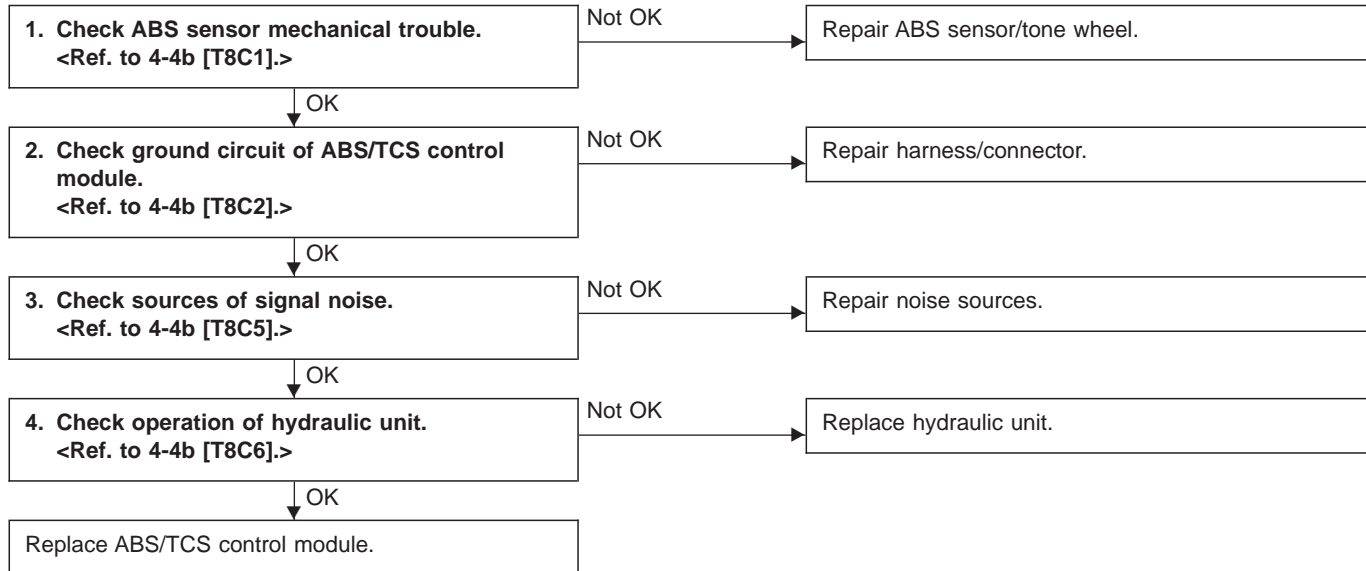

D. ALL 22 (FB1)

FR. SS OVER

B4M0495

3. FR.SS OVER

— Excessive speed of front right ABS sensor signal —

DIAGNOSIS:

- Faulty ABS sensor signal (noise, irregular signal, etc.)
- Faulty harness/connector
- Faulty ABS/TCS control module

TROUBLE SYMPTOM:

- ABS and TCS do not operate.

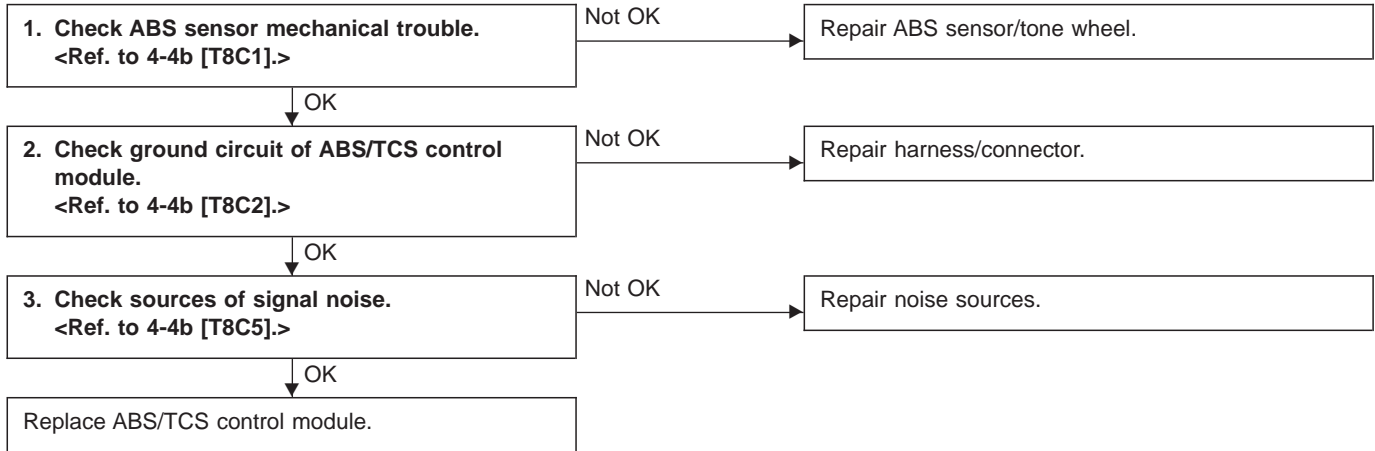

D . ALL 23 (FB1)

FL . SS OPEN

B4M0496

F: TROUBLE CODE 23

1. FL.SS OPEN

— Faulty front left ABS sensor (Open circuit) —

DIAGNOSIS:

- Faulty ABS sensor
- Faulty harness and connector
- Faulty ABS/TCS control module

TROUBLE SYMPTOM:

- ABS and TCS do not operate.

NOTE:

The procedures used are the same as those for FR.SS OPEN.

<Ref. to 4-4b [T10D1].>

D . ALL 23 (FB1)

FL . SS SHORT

B4M0497

2. FL.SS SHORT

— Faulty front left ABS sensor (Short circuit) —

DIAGNOSIS:

- Faulty ABS sensor
- Faulty harness and connector
- Faulty ABS/TCS control module

TROUBLE SYMPTOM:

- ABS and TCS do not operate.

NOTE:

The procedures used are the same as those for FR.SS SHORT.

<Ref. to 4-4b [T10D2].>

D . ALL 24 (FB1)

FL . SS W . SPEED

B4M0498

G: TROUBLE CODE 24

1. FL.SS W.SPEED

— Irregular signals from front left ABS sensor —

DIAGNOSIS:

- Faulty ABS sensor signal (noise, irregular signal, etc.)
- Faulty harness/connector
- Faulty ABS/TCS control module

TROUBLE SYMPTOM:

- ABS and TCS do not operate.

NOTE:

The procedures used are the same as those for FR.SS W.SPEED.

<Ref. to 4-4b [T10E1].>

D . ALL 24 (FB1)

FL . SS OR MV

B4M0499

2. FL.SS OR MV

— Irregular signals from front left ABS sensor in decompressing mode —

DIAGNOSIS:

- Faulty ABS sensor signal (noise, irregular signal, etc.)
- Faulty hydraulic unit
- Faulty harness/connector
- Faulty ABS/TCS control module

TROUBLE SYMPTOM:

- ABS and TCS do not operate.

NOTE:

The procedures used are the same as those for FR.SS OR MV.

<Ref. to 4-4b [T10E2].>

D . ALL 24 (FB1)

FL . SS OVER

B4M0500

3. FL.SS OVER

— Excessive speed of front left ABS sensor signal —

DIAGNOSIS:

- Faulty ABS sensor signal (noise, irregular signal, etc.)
- Faulty harness/connector
- Faulty ABS/TCS control module

TROUBLE SYMPTOM:

- ABS and TCS do not operate.

NOTE:

The procedures used are the same as those for FR.SS OVER.

<Ref. to 4-4b [T10E3].>

D . ALL 25 (FB1)

RR . SS OPEN

B4M0501

H: TROUBLE CODE 25

1. RR.SS OPEN

— Faulty rear right ABS sensor (Open circuit) —

DIAGNOSIS:

- Faulty ABS sensor
- Faulty harness and connector
- Faulty ABS/TCS control module

TROUBLE SYMPTOM:

- ABS and TCS do not operate.

NOTE:

The procedures used are the same as those for FR.SS OPEN.

<Ref. to 4-4b [T10D1].>

D . ALL 25 (FB1)

RR . SS SHORT

B4M0502

2. RR.SS SHORT

— Faulty rear right ABS sensor (Short circuit) —

DIAGNOSIS:

- Faulty ABS sensor
- Faulty harness and connector
- Faulty ABS/TCS control module

TROUBLE SYMPTOM:

- ABS and TCS do not operate.

NOTE:

The procedures used are the same as those for FR.SS SHORT.

<Ref. to 4-4b [T10D2].>

D . ALL 26 (FB1)

RR . SS W . SPEED

B4M0503

I: TROUBLE CODE 26

1. RR.SS W.SPEED

— Irregular signals from rear right ABS sensor —

DIAGNOSIS:

- Faulty ABS sensor signal (noise, irregular signal, etc.)
- Faulty harness/connector
- Faulty ABS/TCS control module

TROUBLE SYMPTOM:

- ABS and TCS do not operate.

NOTE:

The procedures used are the same as those for FR.SS W.SPEED.

<Ref. to 4-4b [T10E1].>

D . ALL 26 (FB1)

RR . SS OR MV

B4M0504

2. RR.SS OR MV

— Irregular signals from rear right ABS sensor in decompressing mode —

DIAGNOSIS:

- Faulty ABS sensor signal (noise, irregular signal, etc.)
- Faulty hydraulic unit
- Faulty harness/connector
- Faulty ABS/TCS control module

TROUBLE SYMPTOM:

- ABS and TCS do not operate.

NOTE:

The procedures used are the same as those for FR.SS OR MV.

<Ref. to 4-4b [T10E2].>

D . ALL 26 (FB1)

RR . SS OVER

B4M0505

3. RR.SS OVER

— Excessive speed of rear right ABS sensor signal —

DIAGNOSIS:

- Faulty ABS sensor signal (noise, irregular signal, etc.)
- Faulty harness/connector
- Faulty ABS/TCS control module

TROUBLE SYMPTOM:

- ABS and TCS do not operate.

NOTE:

The procedures used are the same as those for FR.SS OVER.

<Ref. to 4-4b [T10E3].>

D . ALL 27 (FB1)

RL . SS OPEN

B4M0506

J: TROUBLE CODE 27

1. RL.SS OPEN

— Faulty rear left ABS sensor (Open circuit) —

DIAGNOSIS:

- Faulty ABS sensor
- Faulty harness and connector
- Faulty ABS/TCS control module

TROUBLE SYMPTOM:

- ABS and TCS do not operate.

NOTE:

The procedures used are the same as those for FR.SS OPEN.

<Ref. to 4-4b [T10D1].>

D . ALL 27 (FB1)

RL . SS SHORT

B4M0507

2. RL.SS SHORT

— Faulty rear left ABS sensor (Short circuit) —

DIAGNOSIS:

- Faulty ABS sensor
- Faulty harness and connector
- Faulty ABS/TCS control module

TROUBLE SYMPTOM:

- ABS and TCS do not operate.

NOTE:

The procedures used are the same as those for FR.SS SHORT.

<Ref. to 4-4b [T10D2].>

D . ALL 28 (FB1)

RL . SS W . SPEED

B4M0508

K: TROUBLE CODE 28

1. RL.SS W.SPEED

— Irregular signals from rear left ABS sensor —

DIAGNOSIS:

- Faulty ABS sensor signal (noise, irregular signal, etc.)
- Faulty harness/connector
- Faulty ABS/TCS control module

TROUBLE SYMPTOM:

- ABS and TCS do not operate.

NOTE:

The procedures used are the same as those for FR.SS W.SPEED.

<Ref. to 4-4b [T10E1].>

D . ALL 28 (FB1)

RL . SS OR MV

B4M0509

2. RL.SS OR MV

— Irregular signals from rear left ABS sensor in decompressing mode —

DIAGNOSIS:

- Faulty ABS sensor signal (noise, irregular signal, etc.)
- Faulty hydraulic unit
- Faulty harness/connector
- Faulty ABS/TCS control module

TROUBLE SYMPTOM:

- ABS and TCS do not operate.

NOTE:

The procedures used are the same as those for FR.SS OR MV.

<Ref. to 4-4b [T10E2].>

D . ALL 28 (FB1)

RL . SS OVER

B4M0510

3. RL.SS OVER

— Excessive speed of rear left ABS sensor signal —

DIAGNOSIS:

- Faulty ABS sensor signal (noise, irregular signal, etc.)
- Faulty harness/connector
- Faulty ABS/TCS control module

TROUBLE SYMPTOM:

- ABS and TCS do not operate.

NOTE:

The procedures used are the same as those for FR.SS OVER.

<Ref. to 4-4b [T10E3].>

D . ALL 31 (FB1)

FR . IN VALVE

B4M0511

L: TROUBLE CODE 31

FR.IN VALVE

— Faulty front right inlet solenoid valve —

DIAGNOSIS:

- Faulty harness/connector
- Faulty solenoid valve in hydraulic unit
- Faulty ABS/TCS control module

TROUBLE SYMPTOM:

- ABS and TCS do not operate.
- ABS sequence control does not operate.
- TCS sequence control does not operate.
- Air bleeding mode does not operate.

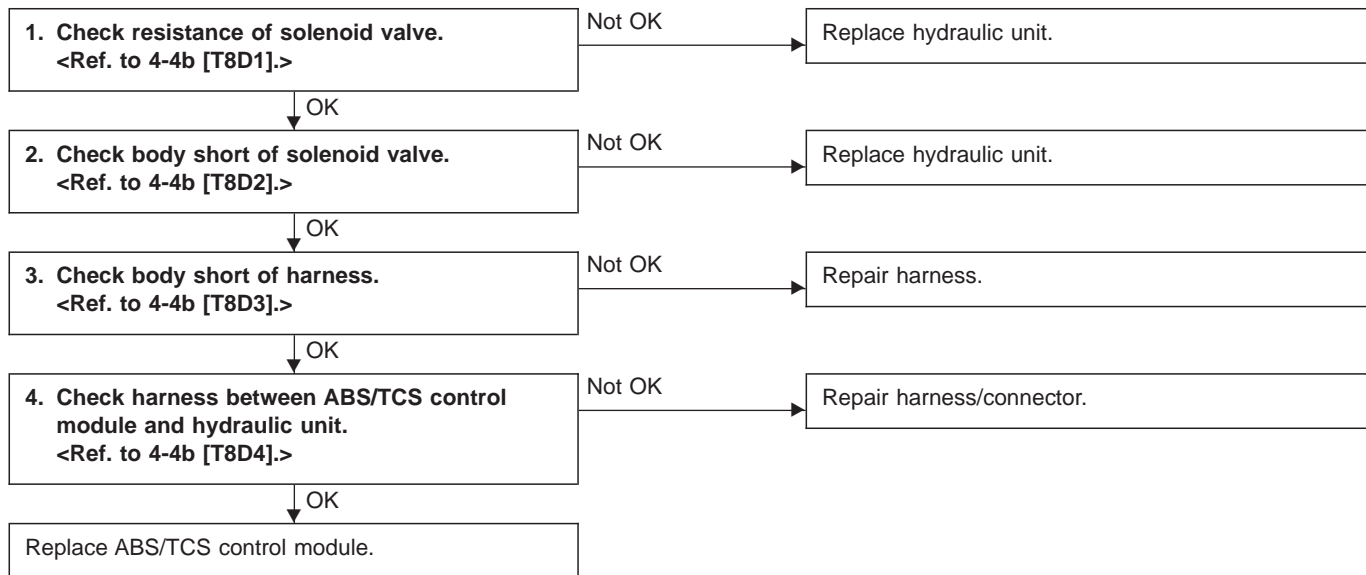

D . ALL 32 (FB1)

FR . OUT VALVE

B4M0512

M: TROUBLE CODE 32

FR.OUT VALVE

— Faulty front right outlet solenoid valve —

DIAGNOSIS:

- Faulty harness/connector
- Faulty solenoid valve in hydraulic unit
- Faulty ABS/TCS control module

TROUBLE SYMPTOM:

- ABS and TCS do not operate.
- ABS sequence control does not operate.
- TCS sequence control does not operate.
- Air bleeding mode does not operate.

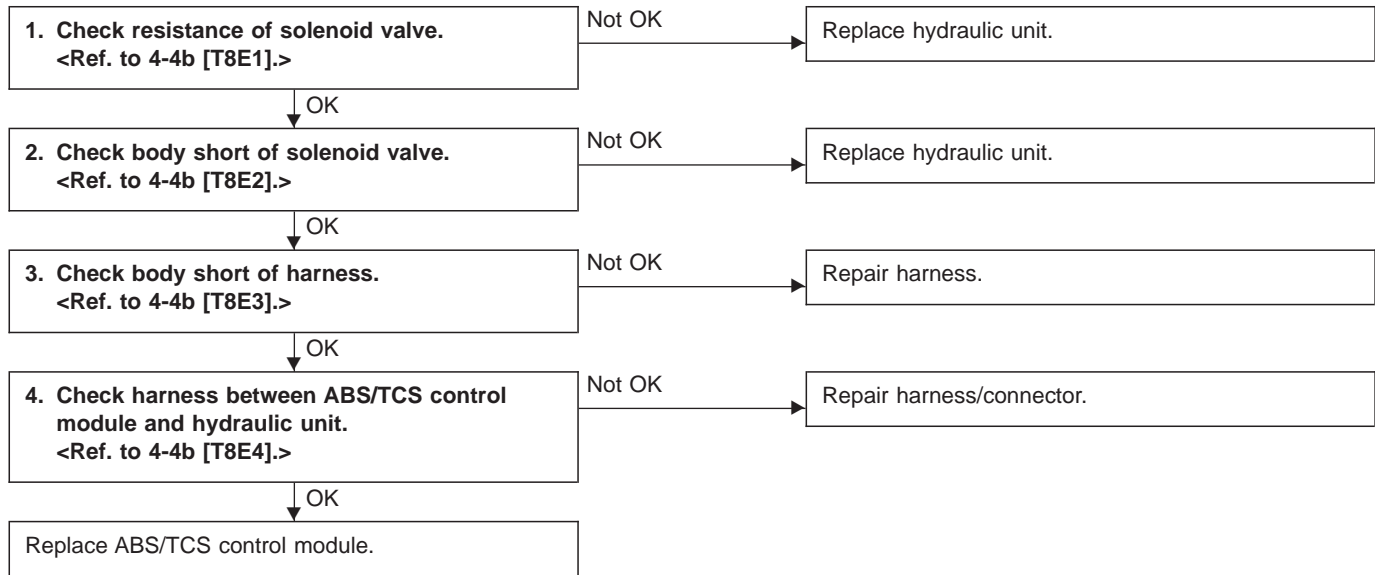

D . ALL 33 (FB1)

FL . IN VALVE

B4M0513

N: TROUBLE CODE 33

FL.IN VALVE

— Faulty front left inlet solenoid valve —

DIAGNOSIS:

- Faulty harness/connector
- Faulty solenoid valve in hydraulic unit
- Faulty ABS/TCS control module

TROUBLE SYMPTOM:

- ABS and TCS do not operate.
- ABS sequence control does not operate.
- TCS sequence control does not operate.
- Air bleeding mode does not operate.

NOTE:

The procedures used are the same as those for FR.IN VALVE.

<Ref. to 4-4b [T10L0].>

D . ALL 34 (FB1)

FL . OUT VALVE

B4M0514

O: TROUBLE CODE 34

FL.OUT VALVE

— Faulty front left outlet solenoid valve —

DIAGNOSIS:

- Faulty harness/connector
- Faulty solenoid valve in hydraulic unit
- Faulty ABS/TCS control module

TROUBLE SYMPTOM:

- ABS and TCS do not operate.
- ABS sequence control does not operate.
- TCS sequence control does not operate.
- Air bleeding mode does not operate.

NOTE:

The procedures used are the same as those for FR.OUT VALVE.

<Ref. to 4-4b [T10M0].>

D . ALL 35 (FB1)

RR . IN VALVE

B4M0515

P: TROUBLE CODE 35

RR.IN VALVE

— Faulty rear right inlet solenoid valve —

DIAGNOSIS:

- Faulty harness/connector
- Faulty solenoid valve in hydraulic unit
- Faulty ABS/TCS control module

TROUBLE SYMPTOM:

- ABS and TCS do not operate.
- ABS sequence control does not operate.
- TCS sequence control does not operate.
- Air bleeding mode does not operate.

NOTE:

The procedures used are the same as those for FR.IN VALVE.

<Ref. to 4-4b [T10L0].>

D . ALL 36 (FB1)

RR . OUT VALVE

B4M0516

Q: TROUBLE CODE 36

RR.OUT VALVE

— Faulty rear right outlet solenoid valve —

DIAGNOSIS:

- Faulty harness/connector
- Faulty solenoid valve in hydraulic unit
- Faulty ABS/TCS control module

TROUBLE SYMPTOM:

- ABS and TCS do not operate.
- ABS sequence control does not operate.
- TCS sequence control does not operate.
- Air bleeding mode does not operate.

NOTE:

The procedures used are the same as those for FR.OUT VALVE.

<Ref. to 4-4b [T10M0].>

D . ALL 37 (FB1)

RL . IN VALVE

B4M0517

R: TROUBLE CODE 37

RL.IN VALVE

— Faulty rear left inlet solenoid valve —

DIAGNOSIS:

- Faulty harness/connector
- Faulty solenoid valve in hydraulic unit
- Faulty ABS/TCS control module

TROUBLE SYMPTOM:

- ABS and TCS do not operate.
- ABS sequence control does not operate.
- TCS sequence control does not operate.
- Air bleeding mode does not operate.

NOTE:

The procedures used are the same as those for FR.IN VALVE.

<Ref. to 4-4b [T10L0].>

D . ALL 38 (FB1)

RL . OUT VALVE

B4M0518

S: TROUBLE CODE 38

RL.OUT VALVE

— Faulty rear left outlet solenoid valve —

DIAGNOSIS:

- Faulty harness/connector
- Faulty solenoid valve in hydraulic unit
- Faulty ABS/TCS control module

TROUBLE SYMPTOM:

- ABS and TCS do not operate.
- ABS sequence control does not operate.
- TCS sequence control does not operate.
- Air bleeding mode does not operate.

NOTE:

The procedures used are the same as those for FR.OUT VALVE.

<Ref. to 4-4b [T10M0].>

D . ALL 41 (FB1)

ECU

B4M0519

T: TROUBLE CODE 41

ECU

— Faulty ABS/TCS control module —

DIAGNOSIS:

- Faulty ABS/TCS control module
- Faulty harness/connector

TROUBLE SYMPTOM:

- ABS does not operate.
- TCS does not operate.

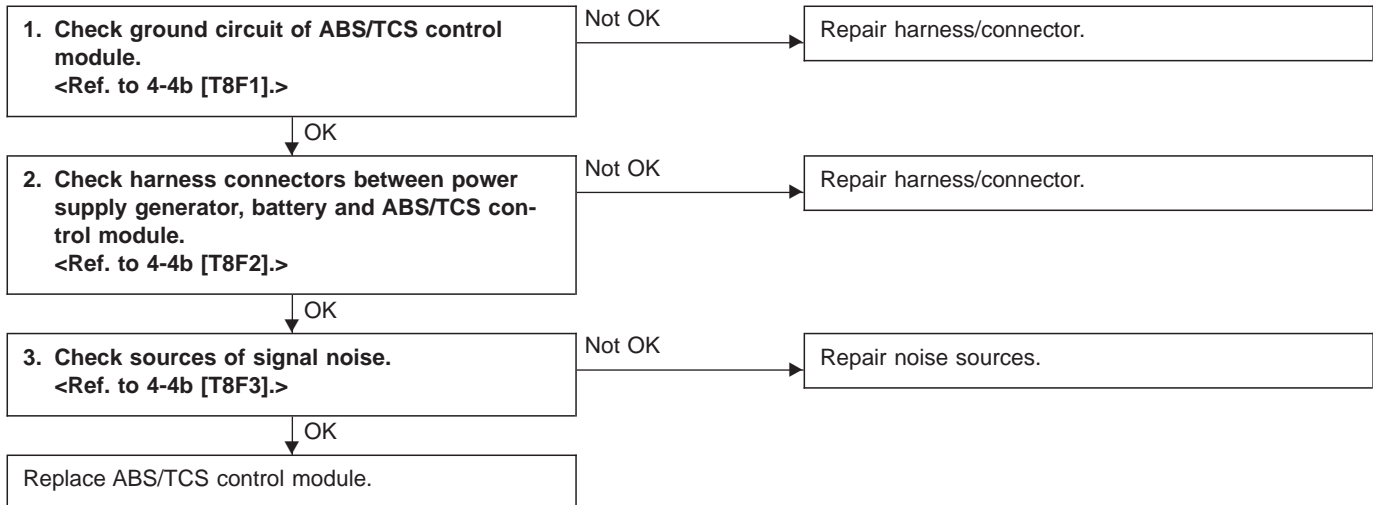

D . ALL 42 (FB1)

HIGH VOLTAGE

B4M0520

U: TROUBLE CODE 42

HIGH VOLTAGE

— Source voltage is high —

DIAGNOSIS:

- Power source voltage of the ABS/TCS control module is more than 18 V.
- Faulty ABS/TCS control module
- Faulty harness/connector

TROUBLE SYMPTOM:

- ABS does not operate.
- TCS does not operate.

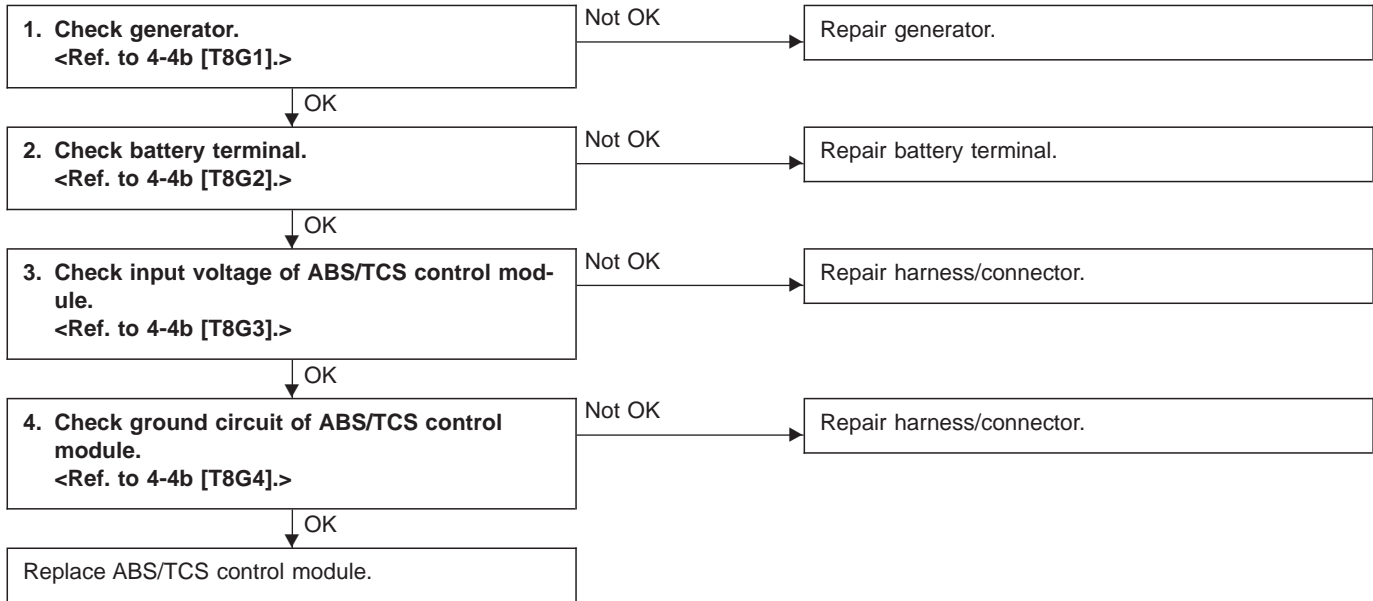

D . ALL 43 (FB1)

EGI LINE

B4M0521

V: TROUBLE CODE 43

EGI LINE

— Faulty engine control module communication cables —

DIAGNOSIS:

- AET communication cable is broken or short circuited.
- AEB communication cable is broken or short circuited.
- AEC communication cable is broken or short circuited.
- Faulty ABS/TCS control module
- Faulty engine control module

TROUBLE SYMPTOM:

- TCS does not operate.

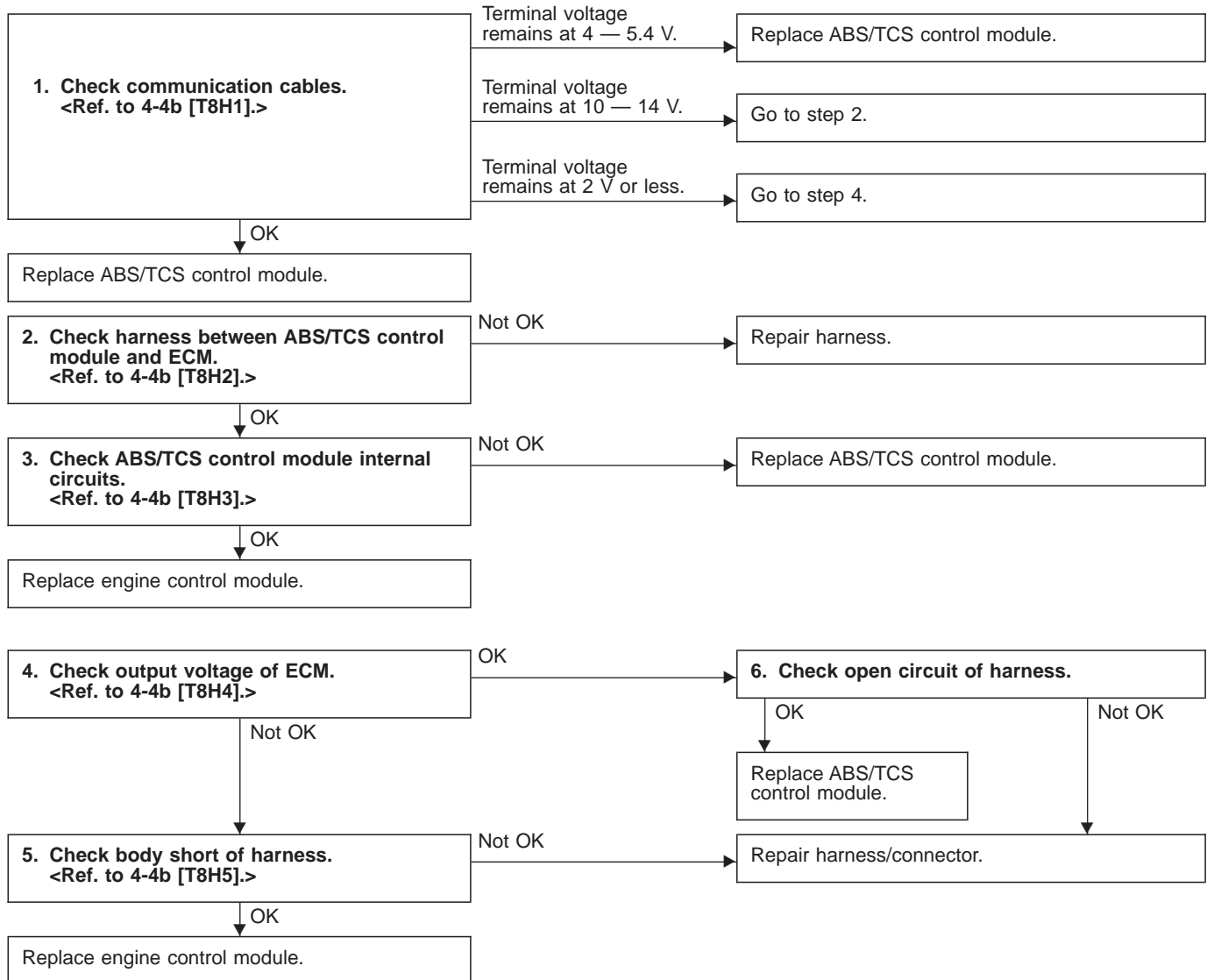

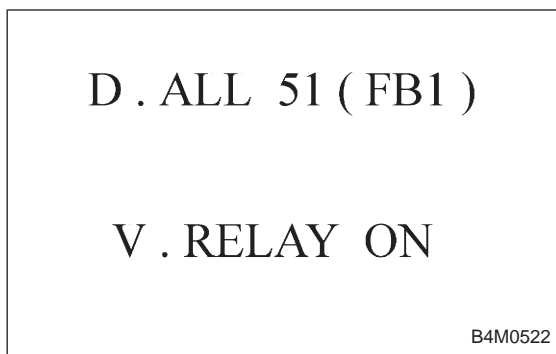

W: TROUBLE CODE 51

1. V.RELAY ON

— Valve relay ON malfunction —

DIAGNOSIS:

- Faulty valve relay
- Faulty harness/connector
- Faulty ABS/TCS control module

TROUBLE SYMPTOM:

- ABS does not operate.
- TCS does not operate.

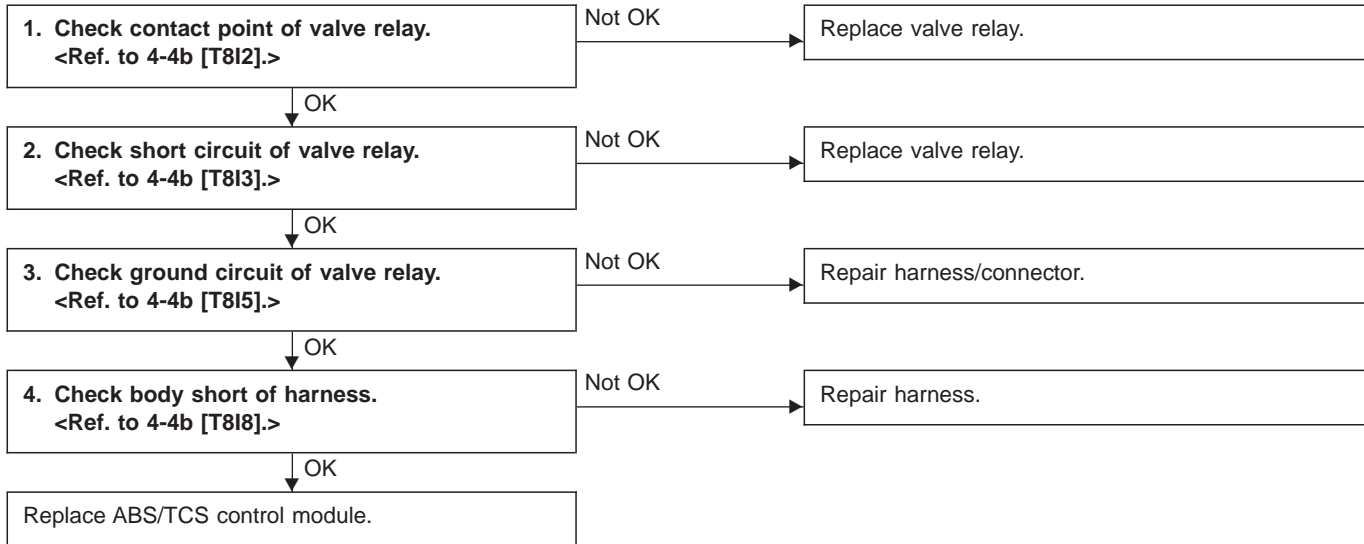

D . ALL 51 (FB1)

V . RELAY OFF

B4M0523

2. V.RELAY OFF

— Valve relay OFF malfunction —

DIAGNOSIS:

- Faulty valve relay
- Faulty harness/connector
- Faulty ABS/TCS control module

TROUBLE SYMPTOM:

- ABS does not operate.
- TCS does not operate.

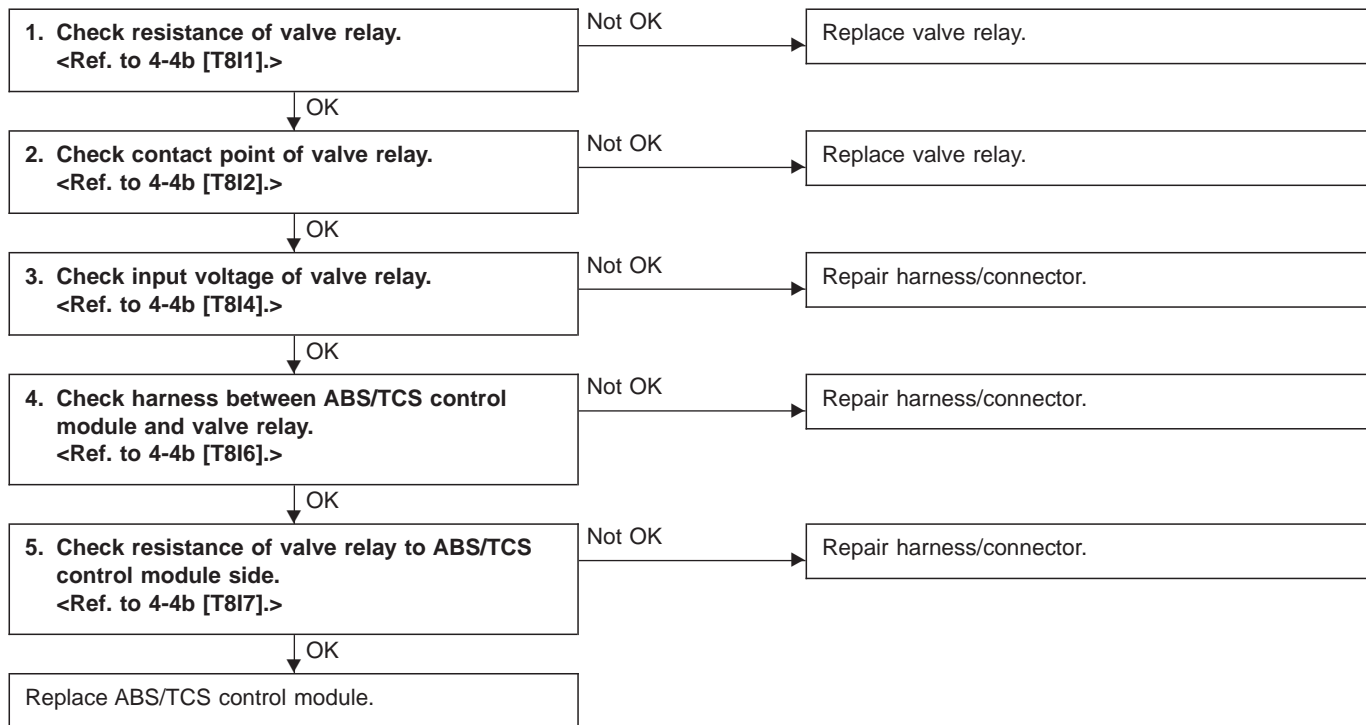

D . ALL 52 (FB1)

MOTOR ON

B4M0524

X: TROUBLE CODE 52

1. MOTOR ON

— Motor relay ON malfunction —

DIAGNOSIS:

- Faulty motor relay
- Faulty motor
- Faulty motor sensor
- Faulty harness
- Faulty ABS/TCS control module

TROUBLE SYMPTOM:

- ABS does not operate.
- TCS does not operate.

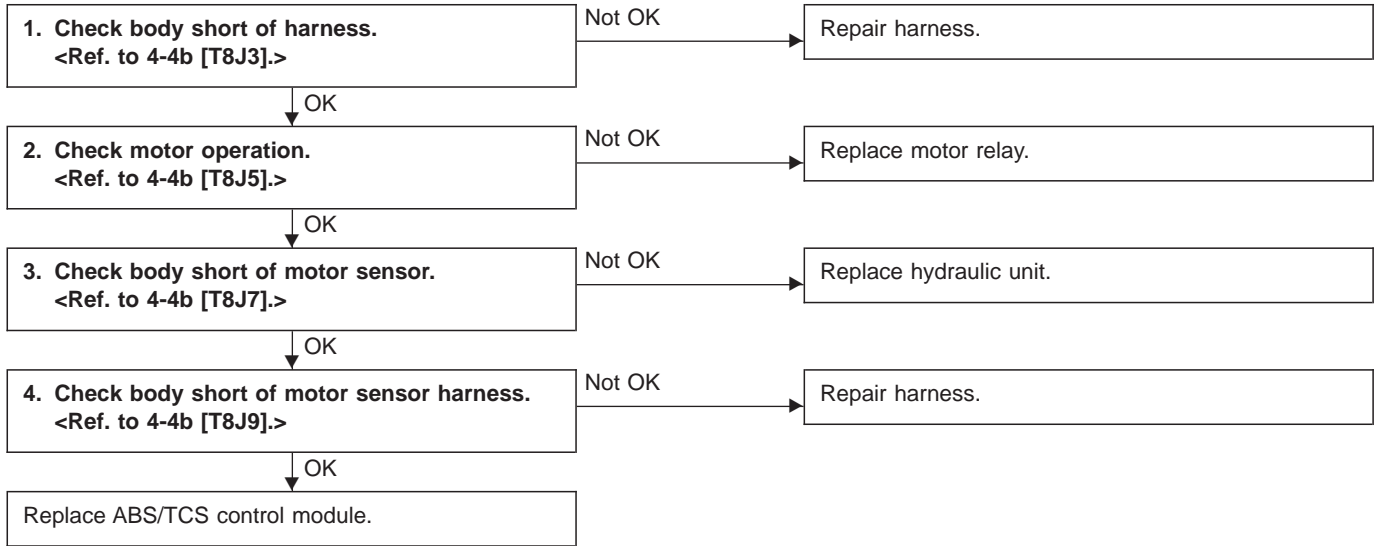

D . ALL 52 (FB1)

MOTOR OFF

B4M0525

2. MOTOR OFF

— Motor relay OFF malfunction —

DIAGNOSIS:

- Faulty motor relay
- Faulty motor
- Faulty motor sensor
- Faulty harness/connector
- Faulty ABS/TCS control module

TROUBLE SYMPTOM:

- ABS and TCS do not operate.

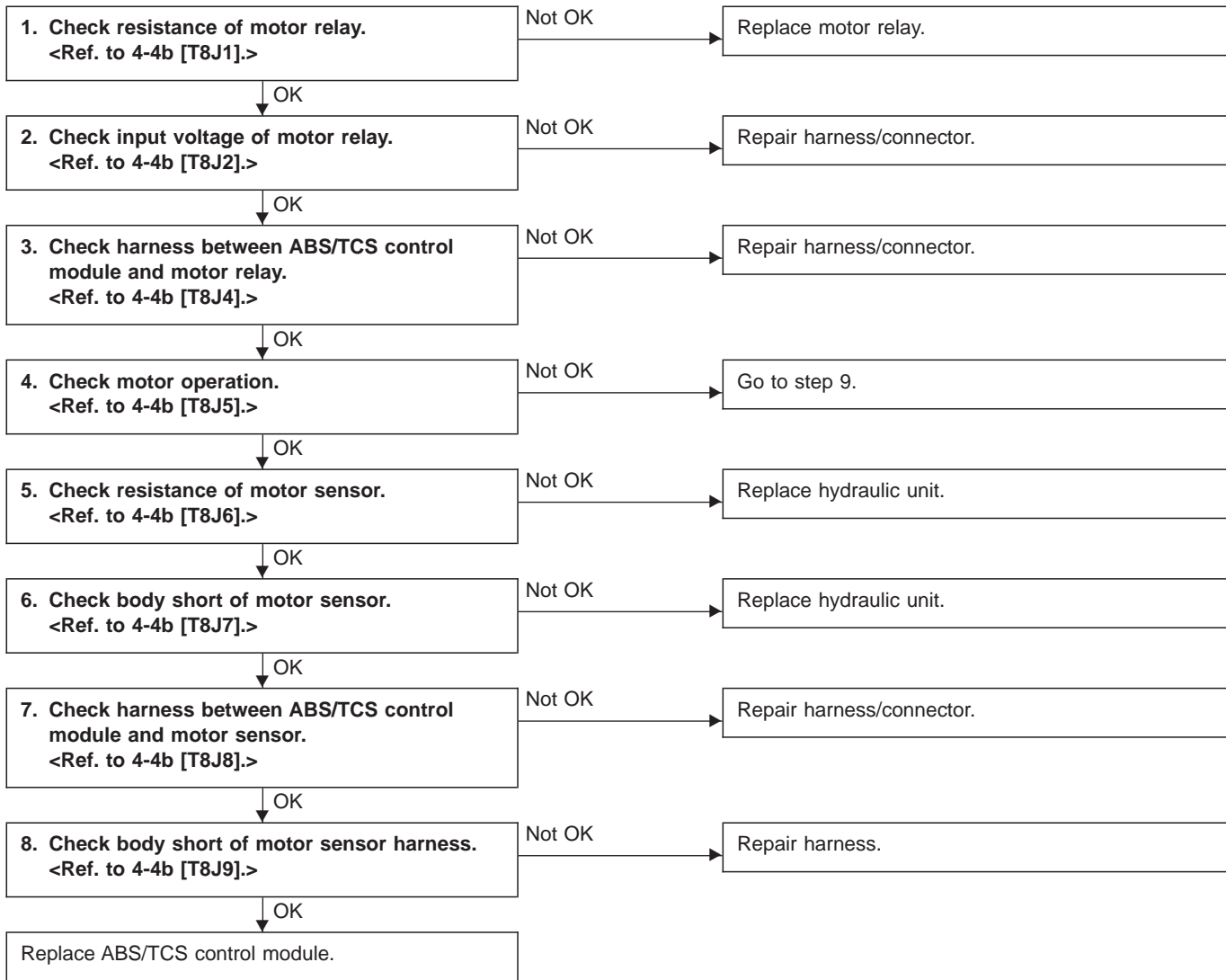

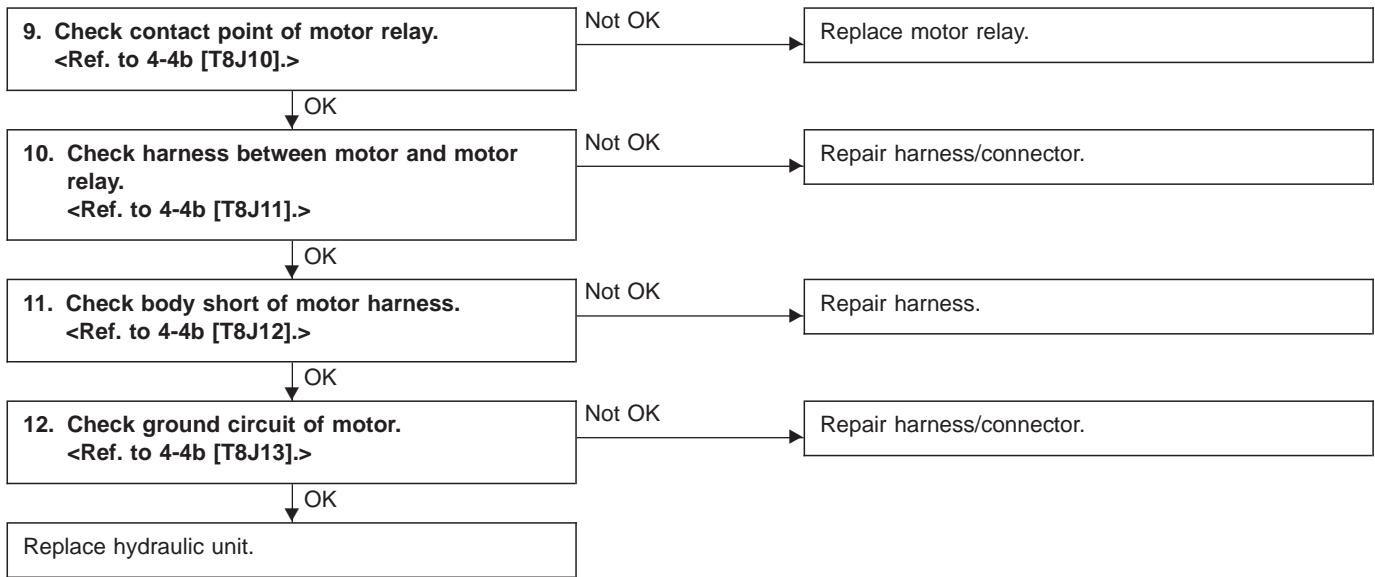
**NOTE:**

The check can also be made by analyzing the sensor output signal with oscilloscope during the TCS sequence control operation. If the ECM female connector end gives correct value, skip steps 5 through 8.

If not, operate the TCS sequence control again and measure the value at motor sensor male connector end, with the motor sensor connector disconnected. If the value is OK, proceed with steps 7 through 8 above.

D . ALL 54 (FB1)

B . SW HARD

B4M0526

Y: TROUBLE CODE 54

1. B.SW HARD

— Break and short circuit at stroke sensor or its wiring —

DIAGNOSIS:

- Faulty stroke sensor
- Faulty harness/connector
- Faulty stop light switch
- Faulty ABS/TCS control module

TROUBLE SYMPTOM:

- ABS and TCS do not operate.

NOTE:

Operate the function F09 in select monitor TCS mode, and read the sensor output step.

If system is normal, the output reading is 1 when brake pedal is not depressed, and it changes from 2 to 3, 4 and 5 in accordance with the brake pedal depressing. If so, skip check steps 1 through 5.

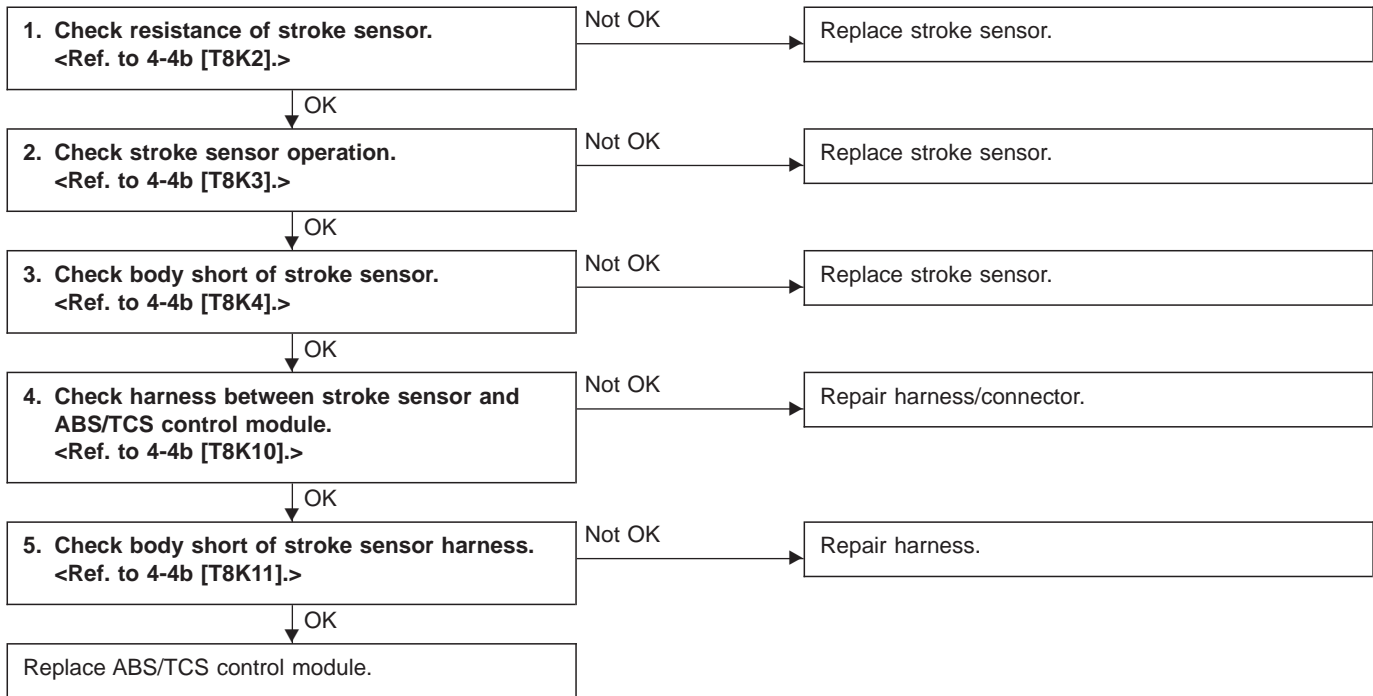

D . ALL 54 (FB1)

B . SW SOFT (G)

B4M0527

2. B.SW SOFT (G)

— Irregular value in comparison stroke sensor and vehicle acceleration comparison —

DIAGNOSIS:

- Faulty stroke sensor
- Faulty harness/connector
- Faulty stop light switch
- Faulty ABS/TCS control module

TROUBLE SYMPTOM:

- ABS and TCS do not operate.

NOTE:

Operate the function F09 in select monitor TCS mode, and read the sensor output step.

If system is normal, the output reading is 1 when brake pedal is not depressed, and it changes from 2 to 3, 4 and 5 in accordance with the brake pedal depressing. If so, skip check steps 2 through 4.

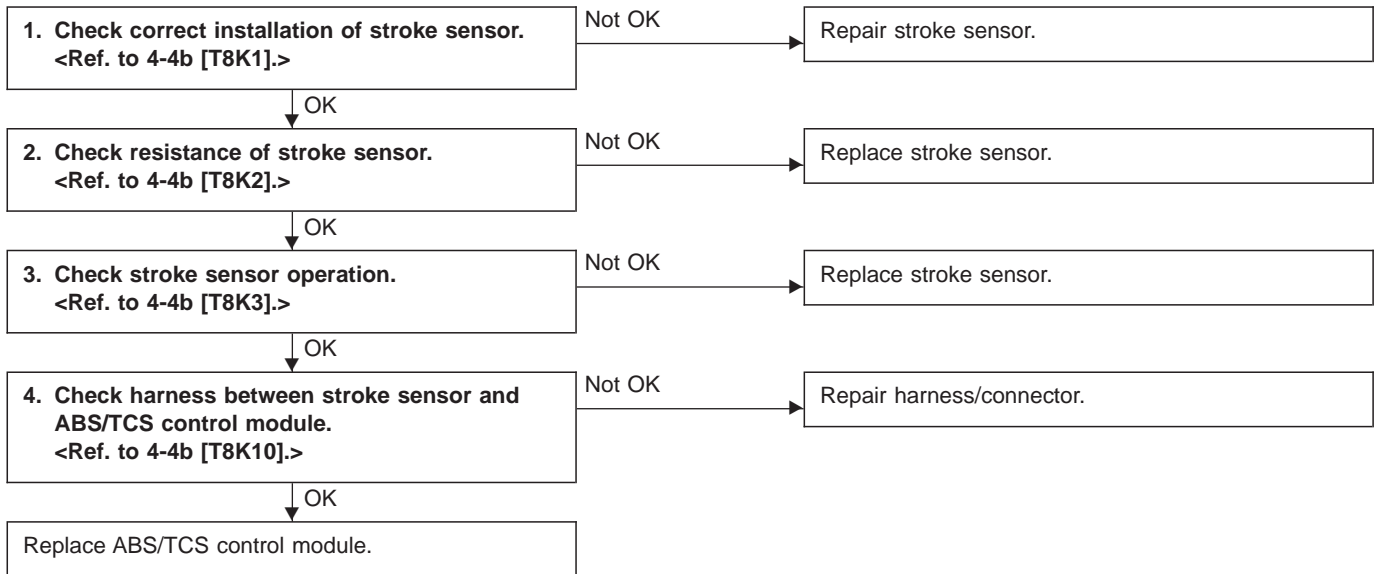

D . ALL 54 (FB1)

B . SW SOFT (B)

B4M0528

3. B.SW SOFT (B)

— Irregular value in stroke sensor and brake light switch comparison —

DIAGNOSIS:

- Faulty stroke sensor
- Faulty stop light switch
- Faulty harness/connector
- Faulty ABS/TCS control module

TROUBLE SYMPTOM:

- ABS and TCS do not operate.

NOTE:

Operate the function F09 in select monitor TCS mode, and read the sensor output step.

If system is normal, the output reading is 1 when brake pedal is not depressed, and it changes from 2 to 3, 4 and 5 in accordance with the brake pedal depressing. If so, skip check steps 1 and 2 through 7.

Then, operate the function FA0 and check the stop and brake switches by B1 LED ON/OFF. If system is normal, LED comes on when depressing brake pedal, and goes off when not depressing. If so, skip check steps 3 through 6.

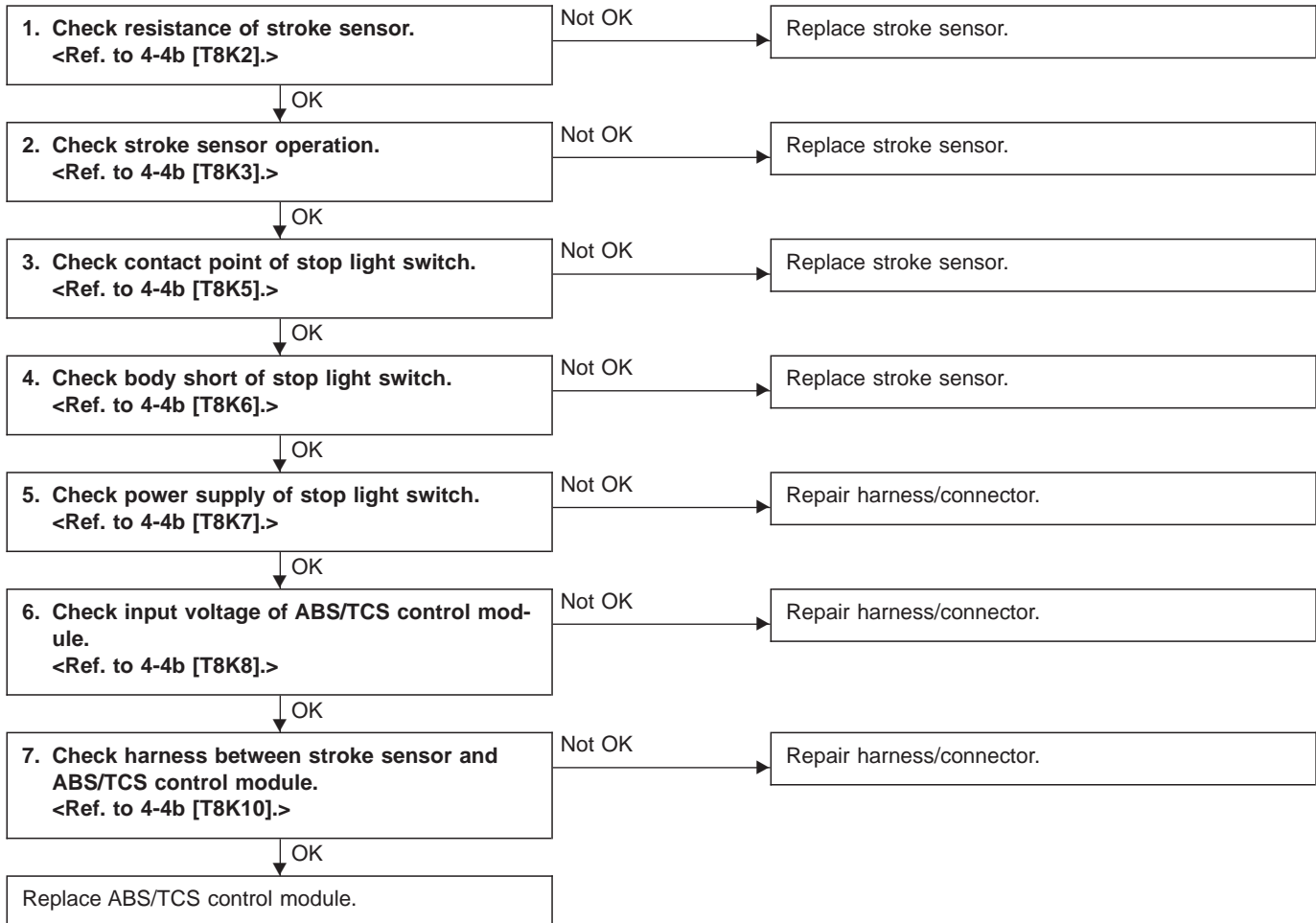

D . ALL 54 (FB1)

B . SW SOFT (P)

B4M0529

4. B.SW SOFT (P)

— Comparison between stroke sensor and pump output —

DIAGNOSIS:

- Faulty stroke sensor
- Faulty harness/connector
- Faulty pump unit in hydraulic unit
- Faulty stop light switch
- Faulty ABS/TCS control module

NOTE:

Operate the function F09 in select monitor TCS mode, and read the sensor output step.

If system is normal, the output reading is 1 when brake pedal is not depressed, and it changes from 2 to 3, 4 and 5 in accordance with the brake pedal depressing. If so, skip check steps 2 through 4.

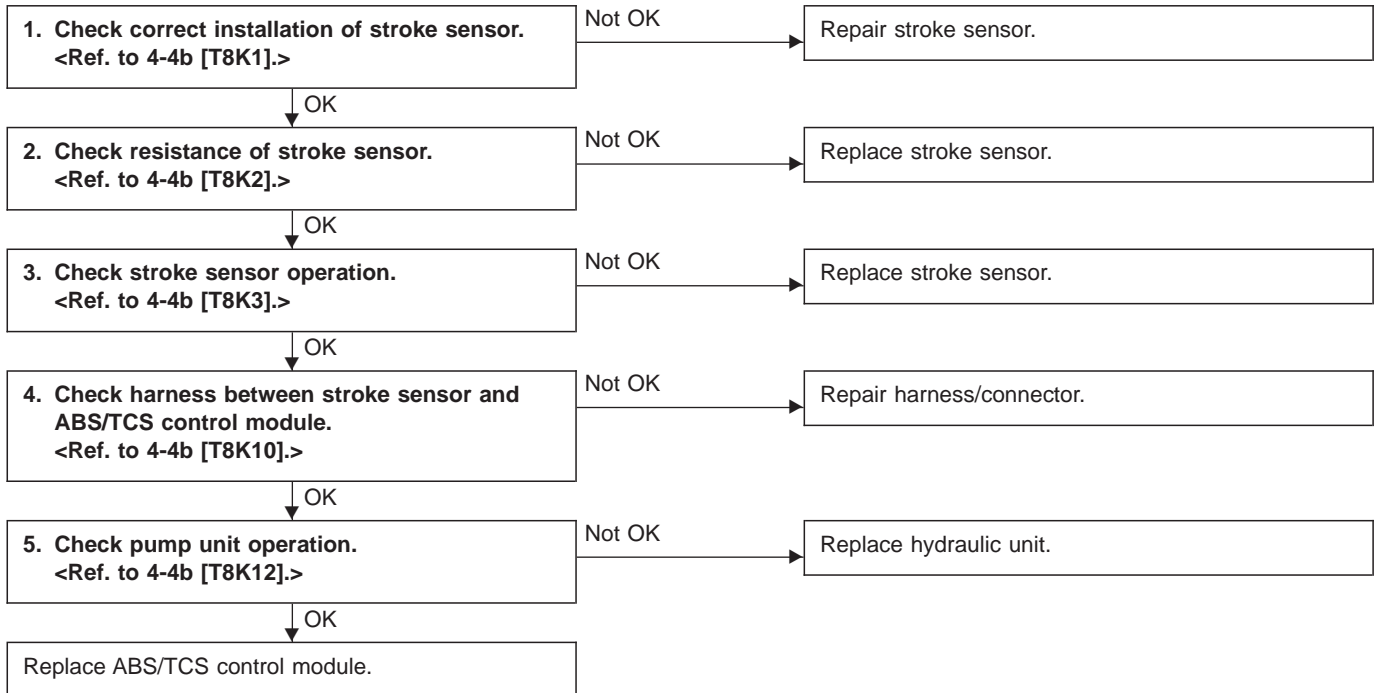

D . ALL 54 (FB1)
 B . SW SOFT (O)
 B4M0530

5. B.SW SOFT (O)

— Broken brake light switch —

DIAGNOSIS:

- Faulty stop light switch
- Faulty harness/connector
- Faulty stroke sensor
- Faulty ABS/TCS control module

TROUBLE SYMPTOM:

- TCS does not operate.

NOTE:

Operate the function FA0 in select monitor TCS mode, and check the stop and brake switches by B1 LED ON/OFF. If system is normal, LED comes on when depressing brake pedal, and goes off when not depressing. If so, skip check steps 2 through 4.

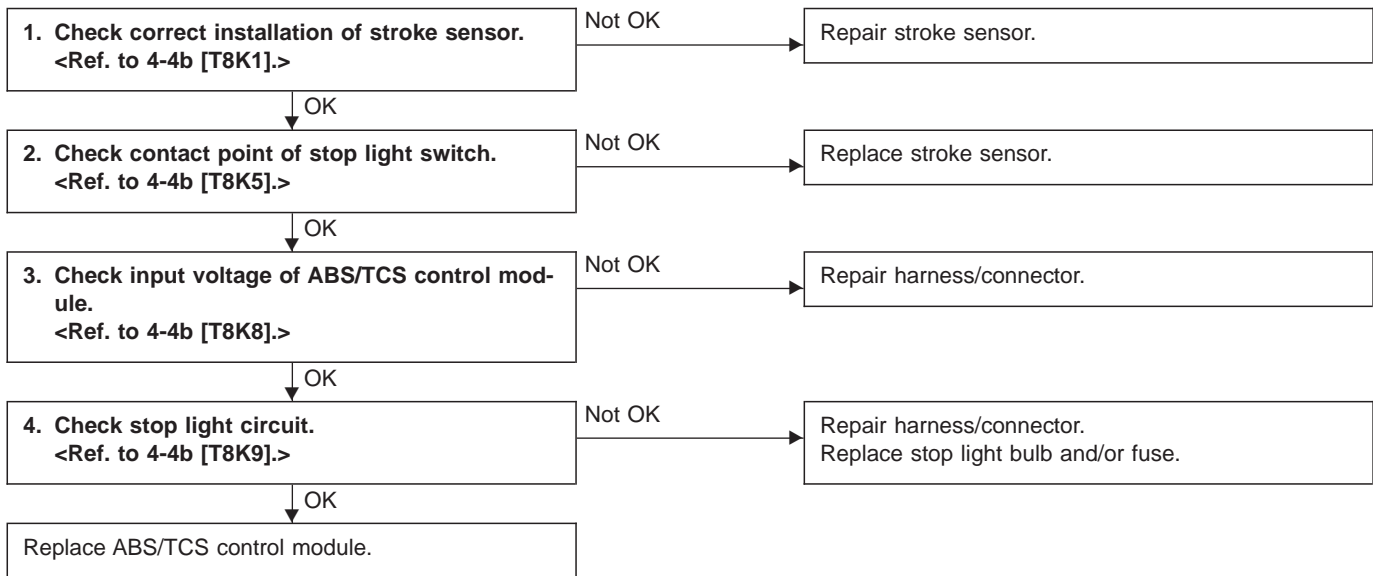

D . ALL 57 (FB1)

FLUID LEVEL SS

B4M0531

Z: TROUBLE CODE 57

FLUID LEVEL SS

— Irregular signal from fluid level sensor —

DIAGNOSIS:

- Faulty fluid level sensor circuit
- Faulty harness/connector
- Faulty ABS/TCS control module
- Faulty generator

TROUBLE SYMPTOM:

- ABS and TCS do not operate.

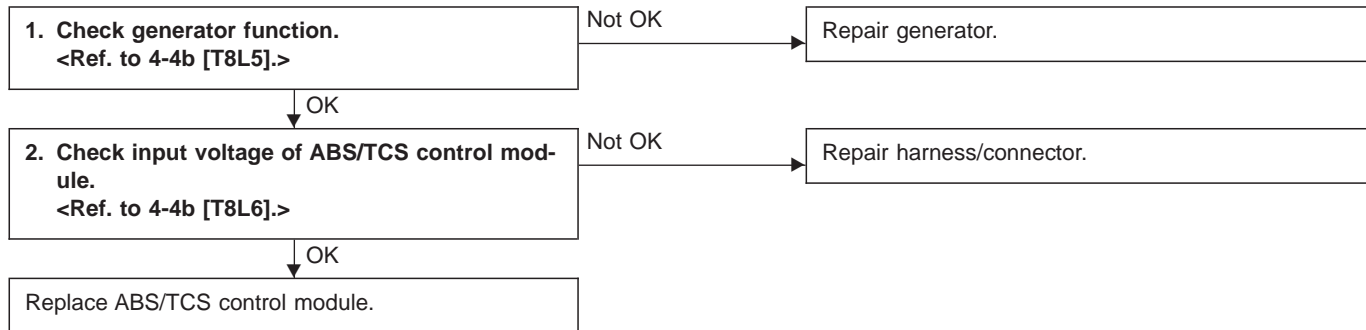

D . ALL 58 (FB1)

PRESSURE SW

B4M0532

AA: TROUBLE CODE 58

PRESSURE SW

— Faulty pressure switch —

DIAGNOSIS:

- Faulty pressure
- Faulty stop light switch
- Faulty ABS/TCS control module
- Faulty harness/connector

TROUBLE SYMPTOM:

- TCS does not operate.

NOTE:

Check using the select monitor.

Operate the function FA0 in select monitor TCS mode. The stop and brake switches can be checked by B1 LED ON/OFF. If system is normal, LED comes on when depressing brake pedal, and goes off when not depressing. If so, skip check steps 5 through 8.

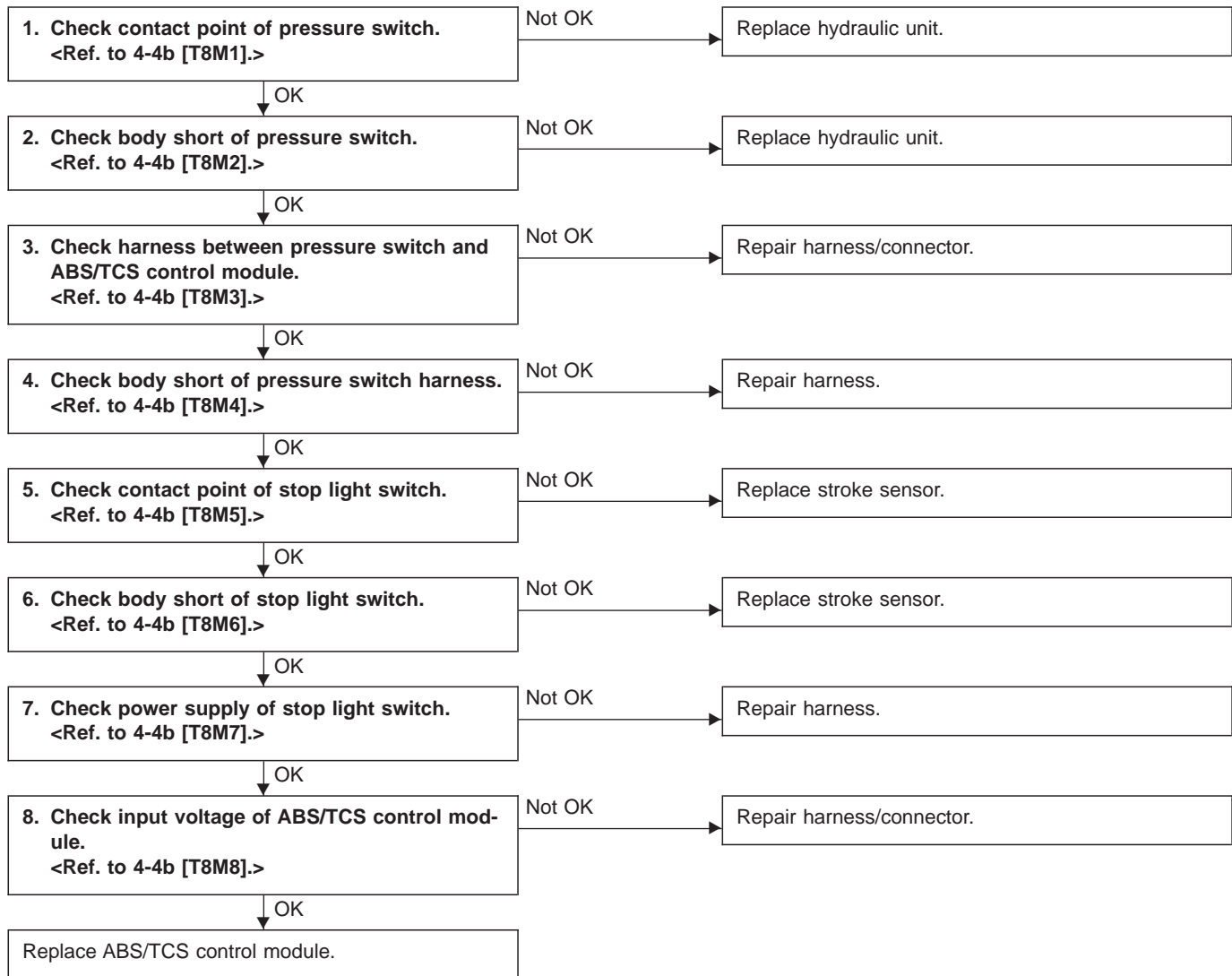

D. ALL 61 (FB1)

TCS1 VALVE

B4M0533

AB: TROUBLE CODE 61

TCS 1 VALVE

— Faulty TCS 1 solenoid valve —

DIAGNOSIS:

- Faulty harness/connector
- Faulty solenoid valve in hydraulic unit
- Faulty ABS/TCS control module

TROUBLE SYMPTOM:

- ABS and TCS do not operate.
- ABS sequence control does not operate.
- TCS sequence control does not operate.
- Air bleeding mode does not operate.

NOTE:

The procedures used are the same as those for FR.IN VALVE.

<Ref. to 4-4b [T10L0].>

D. ALL 62 (FB1)

TCS2 VALVE

B4M0534

AC: TROUBLE CODE 62

TCS 2 VALVE

— Faulty TCS 2 solenoid valve —

DIAGNOSIS:

- Faulty harness/connector
- Faulty solenoid valve in hydraulic unit
- Faulty ABS/TCS control module

TROUBLE SYMPTOM:

- ABS and TCS do not operate.
- ABS sequence control does not operate.
- TCS sequence control does not operate.
- Air bleeding mode does not operate.

NOTE:

The procedures used are the same as those for FR.OUT VALVE.

<Ref. to 4-4b [T10M0].>